

STA-RITE®

POSI*FLO® II FILTER

O W N E R ' S M A N U A L

INSTALLATION, OPERATION & PARTS

MODELS

PTM50 PTM70 PTM100 PTM135

Furnish this manual to the end user of this filter; its use will reduce service calls and chance of injury and will lengthen filter life.

Sta-Rite Pool/Spa Group

293 Wright Street, Delavan, WI 53115

International: 262-728-5551, FAX: 262-728-7550

www.starite.com

Union City, TN • Delavan, WI • Mississauga, Ont. • Murrieta, CA

© 2004, Sta-Rite Industries

Printed in U.S.A.

S294 (Rev. 3/30/04)

STA-RITE POSI*FLO® II FILTERS:

To avoid unneeded service calls, prevent possible injuries, and get the most out of your filter, READ THIS MANUAL CAREFULLY!

The Sta-Rite Posi*Flo® II Series Filter:

- Is designed to filter water for swimming pools, spas and hot tubs.
- Is an excellent performer; durable, reliable.

Table of Contents

Safety Instructions	3
General Information.....	4
Installation - General	5
Installation - Assembling Filter	6-7
Startup	7
Filter Disassembly/Assembly.....	8-9
Filter Cleaning Procedure.....	10
Special Cleaning Instructions.....	10-11
Pool Maintenance.....	11-12
Winterizing.....	12
Troubleshooting Guide	13
Repair Parts List	14
Warranty.....	15

Before installing, open filter to make sure internal air bleed tube and air bleed filter (Key Nos. 13 and 14, Page 14) are in place. Clean air bleed periodically.



⚠ DANGER

⚠ WARNING

⚠ CAUTION

READ AND FOLLOW SAFETY INSTRUCTIONS!

⚠ This is the safety alert symbol. When you see this symbol on your system or in this manual, look for one of the following signal words and be alert to the potential for personal injury.

⚠ DANGER warns about hazards that **will** cause death, serious personal injury, or major property damage if ignored.

⚠ WARNING warns about hazards that **can** cause death, serious personal injury, or major property damage if ignored.

⚠ CAUTION warns about hazards that **will** or **can** cause minor personal injury or property damage if ignored.

NOTICE indicates special instructions not related to hazards.

Carefully read and follow all safety instructions in this manual and on equipment. Keep safety labels in good condition; replace if missing or damaged.

⚠ WARNING **Hazardous pressure** **Incorrectly installed or tested equipment may fail, causing severe injury or property damage. Have a trained pool professional perform all pressure tests.** Read and follow instructions in owner's manual when installing and operating equipment.

1. Do not connect system to a high pressure or city water system.
2. Use equipment only in a pool or spa installation.
3. Trapped air in system can cause explosion. BE SURE all air is out of system before operating or testing equipment.

Before pressure testing, make the following safety checks:

- Check all clamps, bolts, lids, and system accessories before testing.
- Release all air in system before testing.
- Tighten Sta-Rite trap lids to 30 ft. lbs. (4.1 kg-cm) torque for testing.
- Water pressure for test must be less than 25 PSI (172 kPa).
- Water Temperature for test must be less than 100° F. (38° C).
- Limit test to 24 hours. After test, visually check system to be sure it is ready for operation. Remove trap lid and retighten hand tight only.

NOTICE: These parameters apply to Sta-Rite equipment only. For non-Sta-Rite equipment, consult manufacturer.

Component Checklist

(See Page 14)

The carton should contain the following:

- Filter Assembly
- Pressure Gauge
- Air Release Valve Assembly
- Pressure Gauge Screen

If not, please contact Customer Service at 1-800-752-0183.

	⚠ DANGER	BEFORE WORKING ON FILTER:
	If filter clamp is adjusted under pressure, tank will blow off of base, causing severe injury or major property damage.	<ol style="list-style-type: none"> 1. Stop pump. 2. Open air release valve. 3. Release all pressure from system.

GENERAL INFORMATION

⚠ DANGER Hazardous pressure. If filter is improperly disassembled or assembled, it will explode under pressure. To avoid danger of severe injury or major property damage, always follow service instructions in this manual (Pages 8 to 10) when working on filter.

⚠ WARNING Risk of explosion. Never operate this filter system at more than 50 pounds per square inch (50 PSI/345kPa) pressure!

Clean a new pool as well as possible before filling pool and operating filter. Excess dirt and large particles of foreign matter in the system can cause serious damage to the filter and pump.

With a cartridge filter system in place and operating correctly, clean water is returned to the pool faster than the pool water is being contaminated. A typical pool installation will require approximately one week to obtain and maintain the sparkle that your filter is capable of giving you.

Keep pool water pH at recommended level (7.2 to 7.6).

Be sure both clamps are in place and knobs are securely tightened before starting filter.

Maintain pressure gauge in good working order. Replace gauge if it fails or is damaged.

Make sure internal air bleed tube and air bleed filter (Key Nos. 13 and 14, Page 14) are in place before operating filter. Clean air bleed periodically.

Cleaning interval is based on pressure differential, not on length of time filter is operated. Different areas and water conditions will have different normal cleaning intervals.

NOTICE: Some pool disinfectants may clog filter media. To maximize media life and filter cycle time, closely follow disinfectant manufacturer's instructions when cleaning pool or filter.

On a new pool installation, we recommend:

1. Turn to Page 8 for instructions and disassemble the filter after the initial cleanup.
2. Remove and hose down the element assembly to remove contaminants.

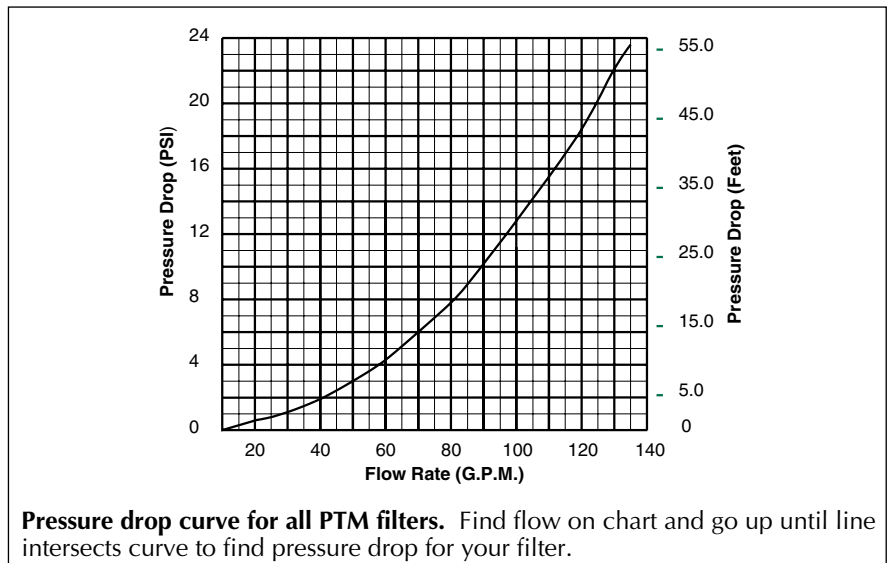

INSTALLATION - GENERAL

Installation of filter should only be done by qualified, licensed personnel.

Filter mount must

Provide space and lighting for easy access for routine maintenance.

Provide adequate ventilation and drainage for pump.

Be protected from weather and reasonably level.

Be less than three feet above pool water level.

Be as close to pool as possible to reduce line loss from pipe friction.

Piping

All piping must conform to local and state plumbing and sanitary codes.

Never use pipe joint sealing compound on pipe and fittings that are plastic or may come into contact with plastic. To seal threaded connections on PVC pipe and fittings, use only Teflon tape, Plasto-Joint Stik* or Silastic RTV #732**; pipe joint compound may cause stress cracking of plastic components. Use pipe joint compounds only on metal-to-metal joints.

Support pipe independently to prevent strains on filter or pump.

Use 1-1/2" or 2" pipe to reduce pressure losses.

NOTICE: Filter locations remote from pool are possible but may require larger pipe to produce adequate flow through filter.

Check local codes if considering a remote installation.

Fittings restrict flow; for best efficiency use fewest possible fittings.

Keep piping tight and free of leaks: pump suction line leaks may cause trapped air in filter tank or loss of prime at pump; pump discharge line leaks may show up as dampness or jets of water.

Valves

A check valve installed between pool and filter outlet will prevent contaminants from draining back into pool.

NOTICE: A check valve between filter and pool will also prevent possible backflow which could dislocate element from its seat.

A check valve installed between filter and heater will prevent hot water from heater from backing up into the filter and deforming filter elements.

NOTICE: Damaging filter elements through excessive heat voids the warranty.

Electrical

BE SURE filter grounding and bonding meets local and National Electrical Code standards. All wiring, grounding and bonding of associated equipment must meet local and National Electrical Code standards.

Before installing, open filter to make sure internal air bleed tube and air bleed filter (Key Nos. 13 and 14, Page 14) are in place. Clean air bleed periodically.

⚠ WARNING



Risk of drowning and falls. Place equipment at least 4 feet from pool so that children cannot climb over it into pool.

Do not allow children to stand or play on filter or pump.

* Lake Chemical Co., Chicago, IL

** Dow Corning

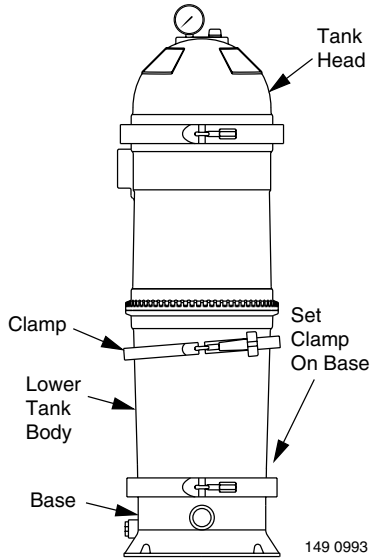

FIGURE 1 – PTM135

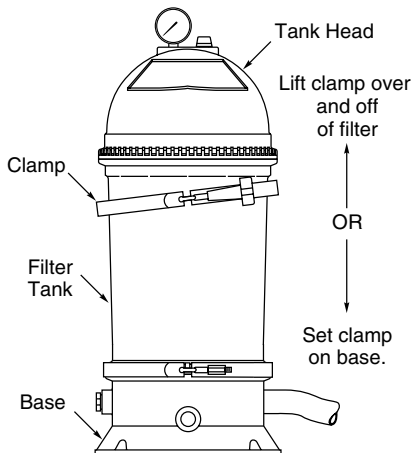

FIGURE 2 – PTM50, PTM70 & PTM100

NOTE: DO NOT pull clamp off outward (sideways) from filter. It will bend and damage the clamp.

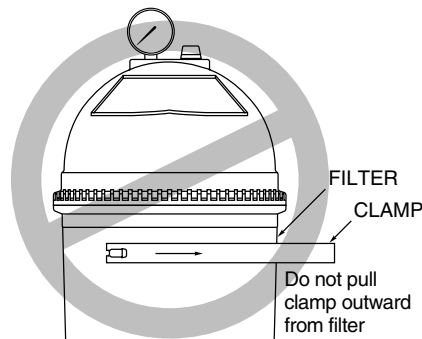

FIGURE 3

Assembling Filter

Filter cartridge may shift position during shipping. To make sure cartridge is in place, follow procedure below before using filter.

When disassembling filter, place all parts in a clean area.

1. Place filter in a clean area near its permanent location.
2. Remove Clamp Fastener from clamp indicated in Figures 1 and 2.
3. Loosen indicated clamp (see Figures 1A and 1B); remove clamp by lifting straight up over tank or dropping it onto filter base (See Figures 1, 2, and 3).
NOTICE: Do not pull clamp sideways to remove; to do so will bend and damage clamp (See Figure 3).
4. Remove tank head from filter. **BE CAREFUL** not to damage O-Ring.
5. Set tank head in a clean place; check for missing or damaged parts.
6. Filter element should be installed with blue end up (marked 'TOP') and red end firmly pressed into base.
7. Be sure air tube filter is seated on top of air bleed tube and tube is seated in base.

8. Replace tank head evenly on filter tank shell for a tight seal.

NOTICE: Be sure O-Ring and O-Ring seating area are clean.

9. Place clamp assembly over flange of tank head and tank body and tighten with clamp knob.

NOTICE: To properly engage tank head and tank body flange with clamp, you may have to push down on top of tank head while installing clamp.

10. Tighten clamp firmly hand tight; tap clamp around tank with rubber hammer while tightening to aid sealing.

11. Attach pressure gauge and air release valve as shown in Figure 4. Apply Teflon tape, Plasto-Joint Stik or Silastic RTV#732 to threads of pressure gauge.

NOTICE: Tighten gauge hand tight only. Tighten air release valve finger tight only.

Connecting Filter Piping

NOTICE: For ease of installation, plastic pipe and fittings are recommended for all piping to and from pool. **DO NOT** use pipe joint compound on base of filter; to do so will cause stress cracking of base, which will void warranty and may cause property damage.

CAUTION Risk of damage to filter. Do not tighten fittings into base ports past thread stops. To do so will ruin filter base and void warranty, and may cause property damage.

NOTICE: If pool or spa/tub water level is higher than filter base, shut-off valves must be installed in suction and return lines.

1. See Figure 5 for piping connections to filter.

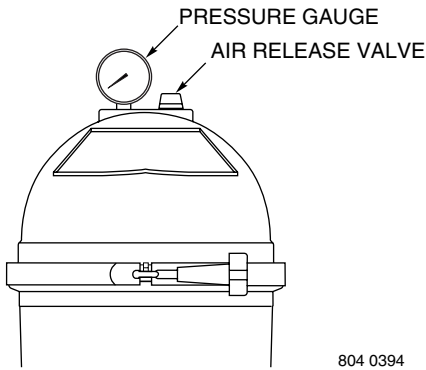

FIGURE 4

2. To make sure all filter base ports are clear, screw all fittings into base hand tight before applying pipe sealer to threads. BE CAREFUL not to cross thread.
3. Wrap 1-1/2 to 2 layers of Teflon tape to male threads only, or use Plasto-Joint Stik or Silastic RTV#732 on all piping and fittings.
4. Hand tighten fitting in each port. Be careful not to cross thread.
5. With wrench, tighten fittings to a snug fit. Be careful not to thread fittings past thread stop.
6. If pipe connections leak, remove, clean off sealant, reapply sealant and retighten in ports. Do not overtighten.

START-UP

⚠ WARNING Hazardous pressure. Risk of severe injury or major property damage if tank explodes. Read the entire procedure before starting system or disassembling filter.

A. Turn pump OFF before starting procedure.

B. Properly seat filter clamps and securely tighten clamp knobs before proceeding.

C. Read decal on tank.

NOTICE: Tightly close plugs or valves in #3 Tank Drain Port and #4 Auxiliary Drain Port.

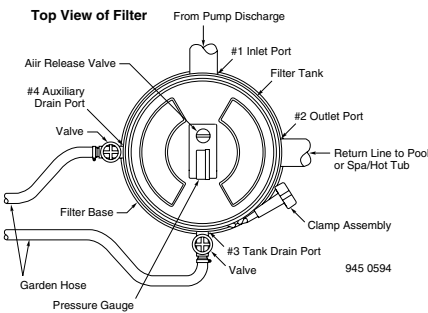

3 tank drain port is used to drain tank prior to normal filter cleaning.

#4 auxiliary drain port is used to drain excess unfiltered water (e.g., from heavy rainfall, etc.) to waste or to drain filter if a heavy dirt load plugs cartridge. Three-quarter inch hose bibs may be fitted to these drains to allow easy drainage of waste water away from filter area.

FIGURE 5

1. Open air release valve (Key No. 2, Page 14) located on top of filter tank head.

NOTICE: Air trapped inside the filter greatly increases the explosion hazard. The air release valve allows you to get accumulated air out of the filter tank. At startup, open the air release valve and make sure that it is running a solid stream of water before putting the filter in service.

2. Start pump.
3. When a steady stream of water comes from air release valve, close valve.
4. After filter is operating, record filter pressure gauge reading in owner's manual for future use.

NOTICE: When installed on a new pool, filter element may need cleaning after approximately 48 hours of operation.

NOTICE: A new or recently cleaned filter element may pass some foreign material until it builds up a sufficient coating to stop all "fines". This is normal; a short operational period will correct the condition.

Check pressure gauge; if pressure has risen more than 10 PSI (70kPa) above startup pressure, remove and clean element.

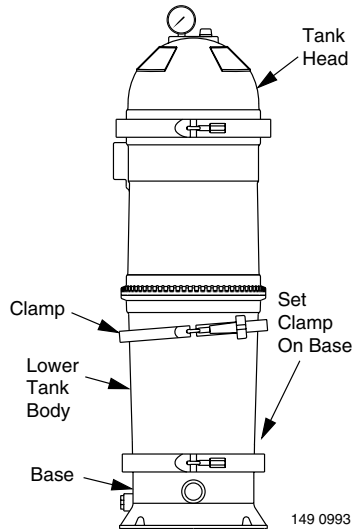

FIGURE 6A – PTM135

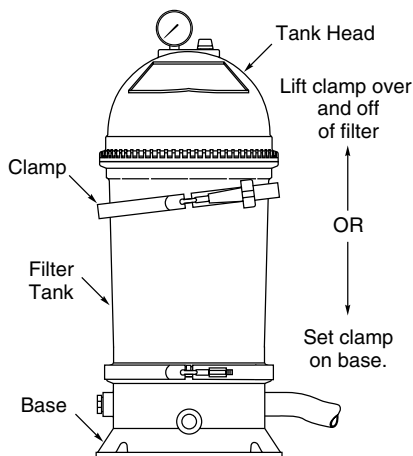

FIGURE 6B – PTM50, PTM70 & PTM100

NOTE: DO NOT pull clamp off outward from filter. It will bend and damage the clamp. See Figure 7.

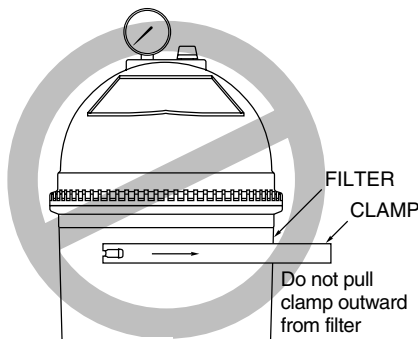

FIGURE 7A

FILTER DISASSEMBLY



Releasing either clamp with pressure on system will cause tank or tank head to blow off of base, causing severe injury or major property damage. **NEVER** adjust, tighten or loosen either “V” band clamp when tank is under pressure. If filter leaks at the clamp, do not adjust the clamp. Instead, follow instructions under “Filter Disassembly”, below and “Filter Assembly”, Page 9.

- ⚠ **Regularly inspect clamp assemblies for cracked, corroded, or broken welds and worn or stripped threads.** If any wear or damage shows, replace the complete clamp.
- ⚠ **Tension stresses and aggressive pool chemicals can aggravate mechanical wear.** Tank clamp assemblies and nuts or plastic knobs should be replaced every five years.
- ⚠ **Do not use a filter that shows cracks, corrosion, or distortion.**

If you are unsure of the condition of your filter, consult your pool professional or call: Sta-Rite Customer Service 1-800-752-0183

Filter Disassembly:

1. **STOP PUMP.**
2. **CLOSE** suction and return line valves (if used).
3. **OPEN** air release valve on top of filter.
4. **WAIT** until all pressure is released from filter tank and system before loosening either clamp.
5. Remove drain plug or open drain valve at ‘Tank Drain Port’ and drain filter.

⚠ WARNING To prevent severe or fatal injury, make sure that all pressure has been released from filter tank before proceeding.

6. Remove clamp fastener from clamp indicated in Figures 6A and 6B.
7. Loosen indicated clamp (see Figure 6); remove clamp by lifting it straight up over tank or dropping it onto filter base. (see Figures 6A, 6B, 7A, and 7B, Pages 8 and 9).

NOTICE: Do not pull clamp sideways to remove; to do so will bend and damage clamp.

8. Remove tank head from tank body. Be careful not to damage “O” Ring. Place tank head in clean area.

NOTICE: If heavy dirt deposits have collected around bottom of filter element and base, wash out base before removing element.

9. Remove the O-Ring from the filter. Clean the O-Ring and inspect it. If you see cuts, cracking, deformation, or wear, replace it.
10. Rock filter element to one side (see Figure 8) to free seal.
11. Lift element out of tank body (See Figure 9). Do not drop filter element. Place element in clean area where it can be hosed down.
12. Remove air bleed filter from tube and clean it.

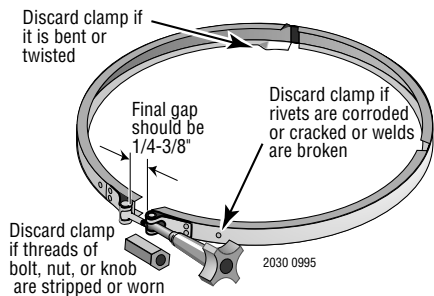

FIGURE 7B – Clamp Inspection Procedure

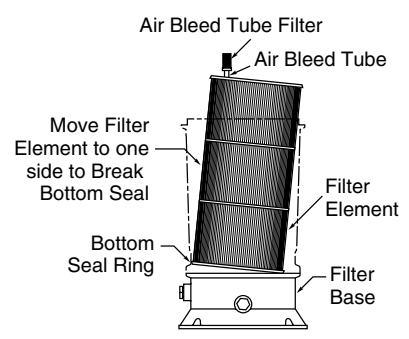

FIGURE 8

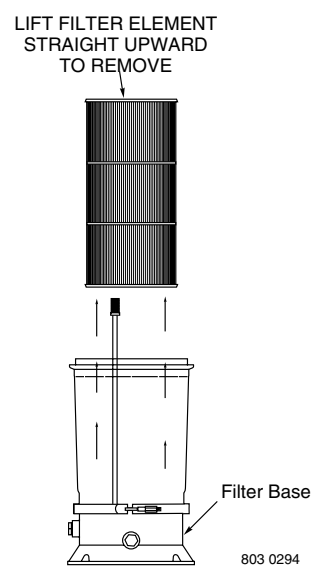

FIGURE 9

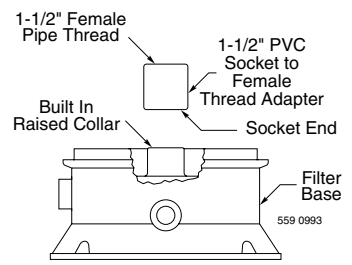

FIGURE 10

ADAPTER INSTALLATION

Use PVC cement to attach a 1-1/2" PVC socket-to-thread adapter (not supplied) to raised collar on filter base to allow attachment of an elbow and hose for:

1. vacuuming pool, putting water to waste (see Page 12);
2. draining;
3. lowering water level in pool or spa/tub (see Figure 17).

▲ WARNING Flammable and poisonous fumes. Use cement only in a well ventilated area away from flame; follow manufacturer's instructions.

FILTER ASSEMBLY

1. Replace plugs or close valves in Tank Drain and Auxiliary Drain ports.
 2. Push clean air bleed filter all the way down on tube. If tube has been removed, push it into socket seat in base until it bottoms.
 3. Set filter element on base.
- NOTICE:** Be sure blue end marked "TOP" is on top and red end is on bottom. Do not reverse element.
4. Push filter element into base between two circular ribs until it bottoms.
 5. Inspect and clean the tank flanges and upper and lower O-Ring seats. If flanges are deformed, cracked, or corroded, replace entire filter.
 6. Reinstall O-Ring. Reinstall tank head. See below for a list of approved O-Ring lubricants.

NOTICE: On multiple-clamp units, clamp/O-Ring sets are not interchangeable. When replacing more than one clamp, refer to Parts List, Page 14, for correct location.

▲ CAUTION Do not remove or damage safety and instruction labels during cleaning. Replace any decals which may have been damaged.

7. If bottom clamp was removed, BE SURE bottom of tank body is clean; set tank body evenly on base and "O" Ring.
8. Install clamp(s) and knob assembly(s); Tighten clamps equipped with **knobs** firmly hand tight. Tighten clamps equipped with **nuts** to 20-30 in. lbs. (23-35 cm-kg) torque. The final gap between the clamp ends should be 1/4 to 3/8" (6 to 9.5 mm).
9. Clean pump strainer basket.
10. Open system valves as needed.
11. Proceed to "Startup", Page 7.

STA-RITE APPROVED O-RING LUBRICANTS

Petroleum Jelly (Vaseline)	Semi-Permanent Lubrication
Parker Super-O-Lube*	Semi-Permanent Lubrication
Aqua-Lube by Allube**	Semi-Permanent Lubrication
5% or less Mild Soap Solution	Assembly Lubrication

* Parker Seal Group, Lexington, KY
 ** Allube Div. of Far Best Corp., Los Angeles, CA

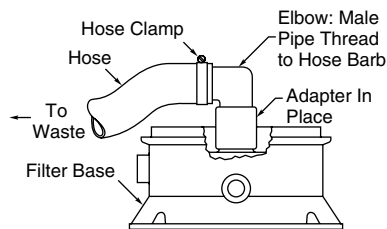

FIGURE 11

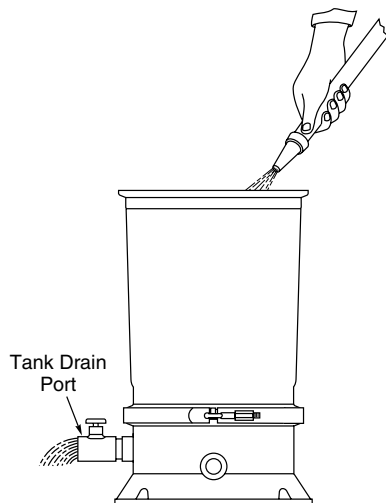

FIGURE 12

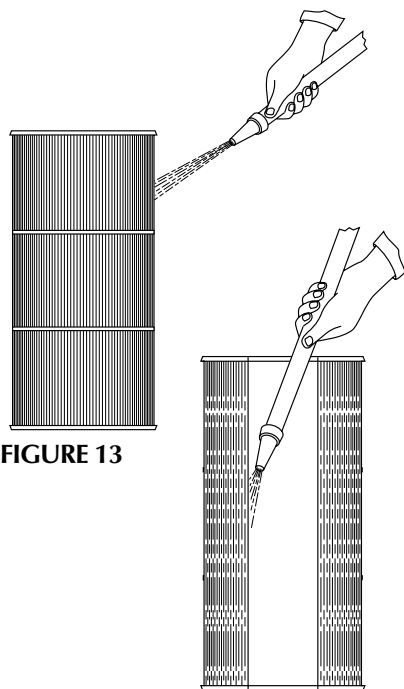

FIGURE 14

FILTER CLEANING PROCEDURE

NOTICE: Keep track of filter operating pressure. When pressure reaches 10 pounds per square inch (PSI) (70kPa) above initial operating pressure, clean filter element.

NOTICE: When sanitizing your pool using PHMB (polyhexamethylene biguanide based) sanitizers, use only PHMB cleaners to clean the module. When using PHMB sanitizers, the filter module **MUST** be cleaned more thoroughly and frequently than for a pool using chlorine. Follow manufacturer's instructions carefully. Use of any other type of cleaners with PHMB pool sanitizers will void the filter's warranty.

NOTICE: If filter is used with a spa, soak element (see Step 2, "Special Cleaning Instructions") at each regular cleaning.

With hose, wash foreign material from inside of base. Try to avoid washing debris into outlet port (see Figure 12).

NOTICE: Be sure inside surface of base is clean.

Washing Filter Element (See Figures 13 and 14):

1. Use a garden hose with straight flow nozzle to wash down filter element (Figure 13).
2. Work from the top down; wash down all pleats. Wash between all pleats.
3. Turn element while spraying to wash down entire outside of element.
4. Repeat wash down process for inside of filter element. Hold nozzle as close to inside of pleats as possible (Figure 14).

NOTICE: BE SURE all dirt and foreign materials are washed away from **INSIDE** pleats of element.

SPECIAL CLEANING INSTRUCTIONS:

⚠ DANGER Risk of fire or explosion. Isolate filter from system before chemical cleaning; rinse filter and elements completely before returning to service. If filter cannot be isolated, remove media and clean at another location. Follow chemical manufacturer's instructions for use. Do not mix chemicals except as directed by manufacturer. Do not allow cleaning chemicals to mix with or to come in contact with chlorine, bromines, other chemicals, or chemical feed devices.

NOTICE: Some pool disinfectants may clog filter media. To maximize media life and filter cycle time, closely follow disinfectant manufacturer's instructions when cleaning pool or filter.

For stubborn deposits, proceed as follows:

1. Follow Regular Cleaning Procedure (above).
2. If deposits remain, soak element at least one hour with one of the following solutions:
 - A. Commercial filter cleaner (see chart: follow manufacturer's instructions for use), or
 - B. One cup automatic dishwasher detergent to five gallons of water, or
 - C. One cup Tri Sodium Phosphate (TSP) to five gallons of water.
3. Wash off with water to remove oils, dirt and remaining cleaner solution.
4. If filter element does not come clean with this procedure, consult your

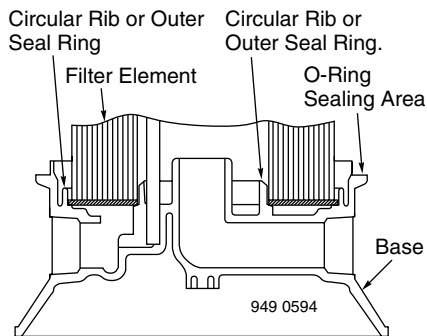

FIGURE 15

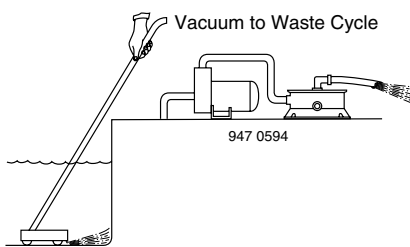

FIGURE 16

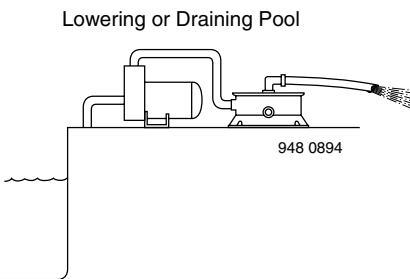

FIGURE 17

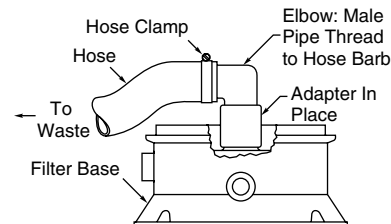

FIGURE 18

pool professional. Acid washing should be done only by trained professionals who have proper safety equipment and acid disposal facilities.

Specialty Filter Cleaners (for Degreasing and Scale Removal)

Filter Cleanse	Great Lakes Biochemical Co. 6120 West Douglas Avenue Milwaukee, WI 53218
Filter Kleen	GFC Chemical Co. P.O. Box 3827 West Palm Beach, FL 33402
Filter Kleen	Haviland Products Co. 421 Ann St. NW. Grand Rapids, MI 49504
Spa Cartridge Filter Clean	Leisure Time Chemical Corp. Los Angeles, CA
KLEEN-IT or Kwik-Strip	Biolab Inc. P.O. Box 1489 Decatur, GA 30031

POOL MAINTENANCE

Vacuum Cycle:

1. Attach vacuum hose to skimmer connection.
2. Adjust suction line valves to provide sufficient flow through vacuum tube.
3. Proceed to vacuum. Filtered water will be recirculated back to pool.

Vacuum to Waste Cycle:

If dirt load in pool has built up to the point that vacuuming to waste (bypassing filter) is desirable, proceed as follows:

1. Disassemble filter.

⚠ DANGER Hazardous pressure. Filter may explode if incorrectly disassembled. To avoid severe injury or major property damage, exactly follow instructions under "Disassembly" (Page 8)!

2. Thread a 1-1/2" 90 degree PVC elbow into female adapter on filter base (see Figure 18).
3. Attach hose to elbow as shown in Figure 18; run hose to waste water disposal area.

NOTICE: Be sure all waste water disposal meets applicable local and state standards and codes.

4. Make sure Tank Drain Port is closed or plugged.
5. Adjust valves on suction pipe for vacuum operation.
6. Attach vacuum hose to skimmer connection.
7. Start filter pump; vacuum pool.
8. Adapter can be left on collar for future cleaning.

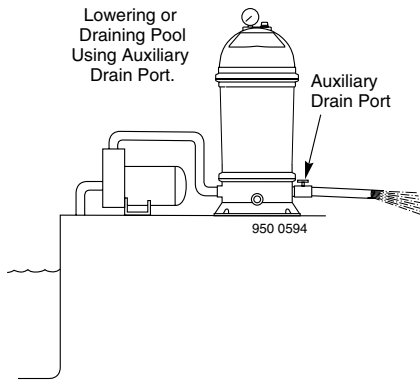

FIGURE 19

Draining or Lowering Pool Through Auxiliary Drain Port

NOTICE: When using “Auxiliary Drain Port” it is not necessary to disassemble filter or remove element.

NOTICE: If pool is being drained, use main drain only. Be sure to close valve in suction pipe leading to skimmers.

1. Stop pump.
2. Attach garden hose or drain hose to Auxiliary Drain Port (see Figure 19). Position hose so that water runs away from pool to wastewater disposal area.
3. Open Auxiliary Drain Port valve.
4. Start pump.
5. Open air release valve (Key No. 2, Page 14).
6. When a steady stream of water flows from air release valve, close valve.

WINTERIZING

⚠ DANGER Hazardous pressure. To avoid severe injury or major property damage, exactly follow instructions below.

⚠ WARNING Explosion hazard. Purging the system with compressed air can cause components to explode, with risk of severe injury or death to anyone nearby. Use only a low pressure (below 5 PSI), high volume blower when air purging the pump, filter, or piping.

NOTICE: Filter must be protected from the weather and drained if freezing is anticipated. Allowing filter to freeze can cause damage to filter and WILL VOID THE WARRANTY!

1. Stop pump.
2. Open air release valve.
3. Remove drain plugs from ports or open valves at “Tank Drain” and “Auxiliary Drain Ports”.
4. Drain ALL piping to and from filter.
 - A. Gravity drain system as far as possible.
 - B. Protect areas which retain water with non-toxic propylene glycol antifreeze (“RV antifreeze”).
5. Turn to Page 8 for filter disassembly instructions.
6. Remove filter element and store in a warm, dry area.

⚠ CAUTION Do not remove or damage safety and instruction labels during cleaning. Replace any decals which may have been damaged.

TROUBLESHOOTING GUIDE

A. Short Cycle:

NOTICE: Time between cleanings will vary with each installation and between different areas of the country. The following causes and remedies are for cycle times shorter than normal for your area.

NOTICE: Some pool disinfectants may clog filter media. To maximize media life and filter cycle time, closely follow disinfectant manufacturer's instructions when cleaning pool or filter.

1. Chlorine residual too low; maintain proper residual (consult pool professional for recommendation).
2. Flow rate too high; restrict flow to rated capacity of filter (see instruction decal on filter).
3. Filter too small; install larger filter or additional filter.
4. Unstable water; consult pool professional.
5. Filter element not cleaned properly or plugged with algae, iron, calcium, etc. - see "Special Cleaning Instructions", Page 10.
6. Heavy or improper application of powdered chlorine or chlorine pills using a binder; see "Special Cleaning Instructions", Page 10.
7. Algae in pool - Apply heavy dose of chlorine or algaecide as recommended by pool manufacturer. Continue until algae is controlled.

B. Low flow:

1. Element is plugged; see "Special Cleaning Instructions", Page 10.
2. Pipe blocked downstream from filter; remove obstruction.
3. Piping too small; replace with larger pipe (consult dealer for recommendation).
4. Pump hair and lint trap is plugged - empty and clean.
5. Pump impeller and diffuser worn - replace with new parts. Consult pump owner's manual for information.
6. Pump too small for system - replace with larger pump.

C. Pool Water Not Clear:

1. Chlorine dosage too low; maintain adequate chlorine residual (consult pool professional for recommendation).

2. Element cloth torn or punctured; replace element.
3. Filter too small, flow too low, or daily operating time too short, giving inadequate turnover rate; consult dealer to verify that equipment is properly sized for your pool.
4. Pump too large - overpumping - reduce flow rate.
5. Filter installed backward - replumb.

D. Long Recovery Time After Heavy Usage:

1. Residual Chlorine level is too low - add chlorine.
2. Filter too small - replace with larger unit.
3. Pump too large - reduce flow rate.

E. Filter Bypasses Dirt:

▲ DANGER To avoid severe injury or major property damage, exactly follow instructions under "Disassembly" and "Assembly" (Pages 8 and 9)!

1. Air bleed tube and/or tube filter not in position. Exactly follow instructions in "Filter Disassembly/Assembly Procedure", Pages 8 and 9, and reinstall correctly.
2. Element cloth torn or punctured; replace element.
3. Filter element is not seated properly in filter base; follow instructions under "Filter Disassembly/Reassembly", Pages 8 and 9, and reposition properly.
4. Filter is plumbed backwards and element cloth is ruptured - replumb properly and replace element.
5. Colloidal fines (very small suspended dirt particles) are present and passing through element covering. Floc with alum, or if fines have already settled, vacuum to waste.

EXPLODED VIEW

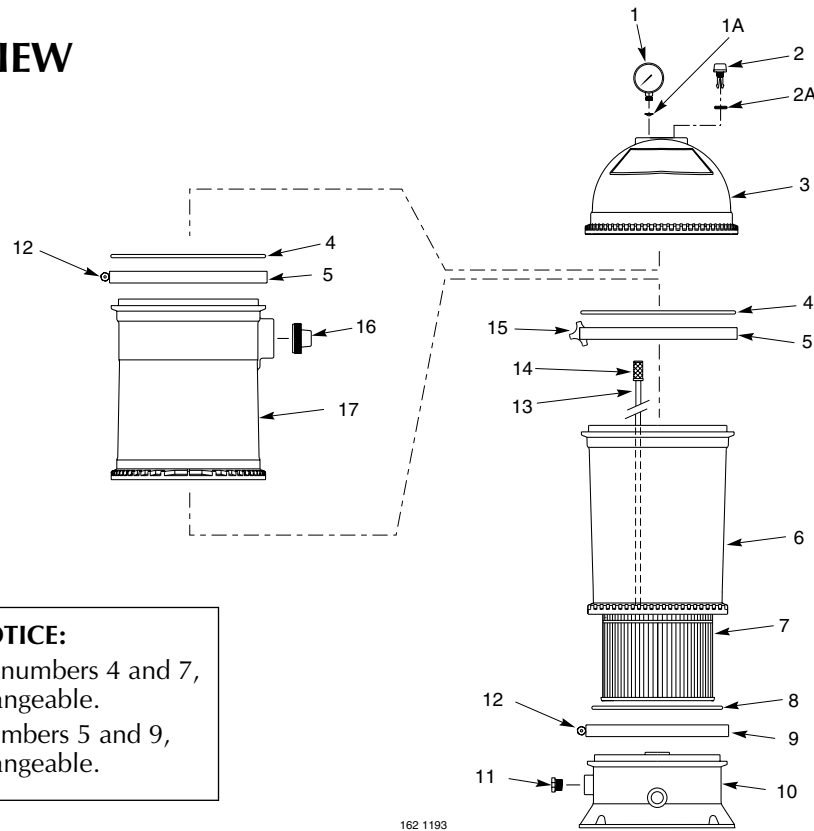

162 1193

REPAIR PARTS LIST

Key No.	Part Description	No. Used	Model PTM50	Model PTM70	Model PTM100	Model PTM135
1	Pressure Gauge	1	15060-0000T	15060-0000T	15060-0000T	15060-0000T
1A	Screen	1	WC8-72D	WC8-72D	WC8-72D	WC8-72D
2	Air Release Valve Ass'y	1	25010-0200	25010-0200	25010-0200	25010-0200
2A	O-Ring	1	U9-359	U9-359	U9-359	U9-359
3	Lid Ass'y (Includes Nos. 1, 1A, 2, and decals)	1	25010-9201	25010-9201	25010-9202	25010-9201
4	"O" Ring *	1	31935-0001	31935-0001	31935-0001	31935-0001
5	Clamp*	1	25010-9101	25010-9101	25010-9101	25010-9101
6	Lower Tank Body	1	25010-0001	25010-0001	25010-0001	25010-0001
7	Filter Element	1	WC108-56S2X	WC108-57S2X	WC108-58S2X	WC108-70S2X
8	"O" Ring	1	WC9-3	WC9-3	WC9-3	WC9-3
9	Clamp	1	25010-9100	25010-9100	25010-9100	25010-9100
10	Base w/Pipe Plugs	1	WC104-78P	WC104-78P	WC104-78P	WC104-78P
11	Pipe Plug	2	WC78-38T	WC78-38T	WC78-38T	WC78-38T
12	Clamp Nut*	1	WC36-1	WC36-1	WC36-1	WC36-1
13	Air Bleed Tube	1	25010-0007	25010-0007	25010-0008	25010-0010
14	Air Bleed Filter	1	WC8-35	WC8-35	WC8-35	WC8-35
15	Clamp Knob	1	WC36-22	WC36-22	WC36-22	WC36-22
16	Plug	1	—	—	—	36305-4032T
17	Upper Tank Body	1	—	—	—	25005-0001
•	Model Decal	1	32155-4040	32155-4041	32155-4042	32155-4066
•	Warning Decal	1	32155-4049	32155-4049	32155-4049	32155-4049
•	Instruction Decal	1	32155-4075	32155-4075	32155-4075	32155-4075
•	Clamp Hazard Decal**	1	WC27-19	WC27-19	WC27-19	WC27-19
•	Air Release Warning Decal**	2	WC27-23	WC27-23	WC27-23	WC27-23
•	Decal: "DO NOT USE PIPE DOPE"	1	WC27-27	WC27-27	WC27-27	WC27-27
•	Decal: "Top Clamp"	1	32165-4036	32165-4036	32165-4036	32165-4036

•Not Illustrated

* Model PTM135 uses 2

** Model PTM135 uses 3.

STA-RITE LIMITED WARRANTY

Pumps, filters, skimmers, underwater lights (except bulbs), accessories and fittings manufactured by Sta-Rite are warranted to be free of defects in material and workmanship for one (1) year from date of installation.

Product specific warranties: **Year from date of installation**

<i>HRPB, DEPB, System 3, System 2 and Posi-Clear</i>	
Tanks	10 years
Internal filter components and valves	1 year
<i>Max-E-Therm - Pool/Spa Heaters</i>	
Heater Enclosure only (Upper RH & LH; lower enclosure; and control board enclosure)...	10 years
<i>Automatic Pool Cleaners including Hose</i>	
	2 years
<i>Cristal-Flo filters - Tanks</i>	
Valve and internal components.	1 year
<i>Posi-Flo II - Tanks</i>	
	10 years
Elements	1 year
<i>PRC Cartridge -</i>	
Filter Tanks	5 years pro-rated (1st 2 years full)
Elements	1 year
<i>System 2 Above Ground Systems - Tanks</i>	
	10 years
Pumps / Platform and Internals	1 year
<i>Pumps</i>	
When equipped with A.O. Smith 2-compartment motors (Does not include pumps sold as part of a systems package)	2 years
<i>Traps / In-Line Strainers</i>	
	1 year
<i>Vertical Commercial Filter - Tanks</i>	
	10 years
Internals	1 year
<i>Horizontal Commercial Filter</i>	
Tanks	5 years
(Years 6-9, Prorated declining 20%/year, Yr. 10 - 10%)	
Internals	1 year

* Full warranty coverage is in effect for one year after installation. The pro-rated warranty covers the *tank only* during the 2nd through 10th year after installation. The amount covered decreases by 10% each year. (ie., 2nd year 90% covered, 3rd year 80% covered, etc.).

The foregoing warranties relate to the original consumer purchaser ("Purchaser") only. Sta-Rite shall have the option to repair or replace the defective product, at its sole discretion. Purchasers must pay all labor and shipping charges necessary to replace the product covered by this warranty. Requests for warranty service must be made through the installing dealer. This warranty shall not apply to any product that has been subject to negligence, misapplication, improper installation or maintenance, or other circumstances which are not in Sta-Rite's direct control.

This warranty sets forth Sta-Rite's sole obligation and Purchaser's exclusive remedy for defective products.

STA-RITE SHALL NOT BE LIABLE FOR ANY CONSEQUENTIAL, INCIDENTAL OR CONTINGENT DAMAGES WHATSOEVER.

THE FOREGOING WARRANTIES ARE EXCLUSIVE AND IN LIEU OF ALL OTHER EXPRESS WARRANTIES. IMPLIED WARRANTIES, INCLUDING BUT NOT LIMITED TO THE IMPLIED WARRANTIES OF MERCHANTABILITY AND FITNESS FOR A PARTICULAR PURPOSE, SHALL NOT EXTEND BEYOND THE DURATION OF THE APPLICABLE EXPRESS WARRANTIES PROVIDED HEREIN.

Some states do not allow the exclusion or limitation of incidental or consequential damages or limitations on how long an implied warranty lasts, so the above limitations or exclusion may not apply to you. This warranty gives you specific legal rights and you may also have other rights which vary from state to state.

Supersedes all previous publications.

Sta-Rite Industries
293 Wright St., Delavan, WI 53115

▲ Retain Warranty Certificate (upper portion) in a safe and convenient location for your records.

DETACH HERE: Fill out bottom portion completely and mail within 10 days of purchase/installation to:

▼ Sta-Rite, Attn: Warranty Dept., 293 Wright St., Delavan, WI 53115

STA-RITE®



Warranty Registration Card

Name _____

Years pool has been in service less than 1 1-3 3-5 5-10 _____

Address _____

Purchased from:
Company name _____

City _____ State _____ Zip _____

Address _____

Purchase Date _____

City _____ State _____ Zip _____

Product Purchased _____

New installation Replacement _____

Please send me more information on these other products from Sta-Rite.

Type of Pool Inground Vinyl Fiberglass Gunite _____

- Pumps Filters Automatic Pool Cleaners
- Maintenance Equipment Test Strips
- Heaters

Size of Pool _____

